

Normal Duty

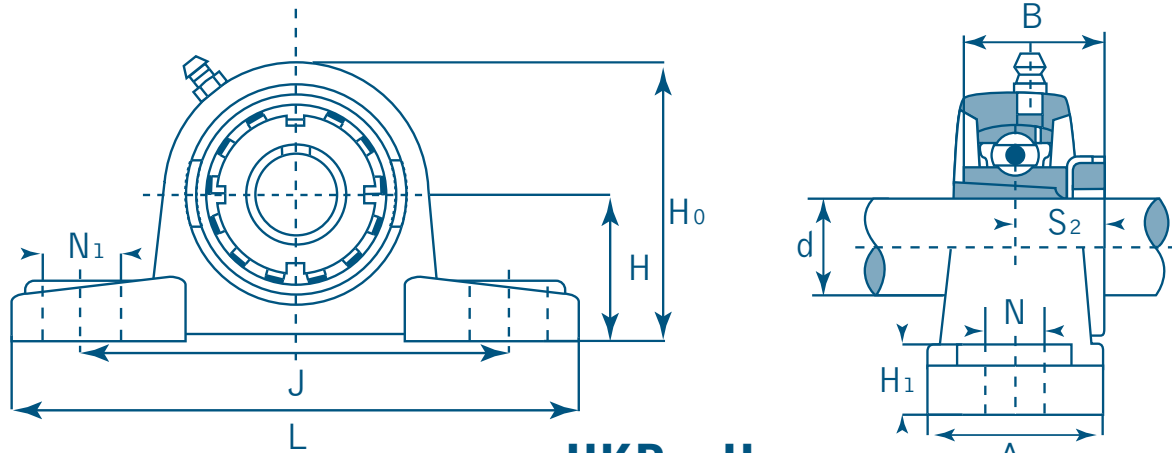

UKP + H
Adapter Sleeve Locking

Unit No.	Shaft Dia. Inch / mm	Dimensions Inch / mm										Bolt Size	Bearing No.	Adaptor No.	Housing No.	Mass	
		H	H ₀	H ₁	L	J	A	N	N ₁	S ₂	B					kg	lbs
UKP 205 + H 2305 + HA 2300 + HE 2305	20 mm 3/4	1-7/16 36.5	2-25/32 71	19/32 15	5-1/2 140	4-1/8 105	1-1/2 38	1/2 13	3/4 19	0.7283 19.5	1-3/88 35	3/8 M 10	UK 205 205	H 2305 HE 2305	P 205	0.86	1.89
UKP 206 + H 2306 + HA 2300 + HE 2306 + HS 2306	25 mm 7/8 15/16 1	1-11/16 42.9	3-5/16 84	43/64 17	6-1/2 165	4-3/4 121	1-7/8 48	43/64 17	25/32 20	0.8071 20.5	1-31/64 38	1/2 M 14	UK 206 206 206 206	H 2306 HA 2300 HE 2306 HS 2306	P 206	1.28	2.82
UKP 207 + H 2307 + HS 2307	30 mm 1-1/8	1-7/8 47.6	3-21/32 93	45/64 18	6-9/16 167	5 127	1-7/8 48	43/64 17	25/32 20	0.8858 22.5	1-11/16 43	1/2 M 14	UK 207 207	H 2307 HS 2307	P 207	1-7/8	4.11
UKP 208 + H 2308 + HE 2308 + HS 2308	35 mm 1-1/4 1-3/8	1-15/16 49.2	3-15/16 100	45/64 18	7-1/4 184	5-13/32 137	2-1/8 54	43/64 17	25/32 20	0.9646 24.5	1-13/16 46	1/2 M 14	UK 208 208 208	H 2308 HE 2308 HS 2308	P 208	1.99	4.38
UKP 209 + H 2309 + HA 2309 + HE 2309 + HS 2309	40 mm 1-7/16 1-1/2 1-5/8	2-1/8 54	4-11/64 106	25/32 20	7-15/32 190	5-3/4 146	2-1/8 54	43/64 17	25/32 20	1.0236 26	1-31/32 50	1/2 M 14	UK 209 209 209 209	H 2309 HA 2309 HE 2309 HS 2309	P 209	1.29	2.84
UKP 210 + H 2310 + HA 2310 + HE 2310 + HS 2310	45 mm 1-5/8 1-11/16 1-3/4	2-1/4 57.2	4-29/64 113	53/64 21	8-1/8 206	6-1/4 159	2-3/8 60	25/32 20	29/32 23	1.0827 27.5	2-11/64 55	5/8 M 16	UK 210 210 210 210	H 2310 HA 2310 HE 2310 HS 2310	P 210	2.83	6.23
UKP 211 + H 2311 + HA 2311 + HE 2311 + HS 2311	50 mm 1-7/8 1-15/16 2	2-1/2 63.5	4-59/64 125	29/32 23	8-5/8 219	6-47/64 171	2-3/8 60	25/32 20	29/32 23	1.1220 28.5	2-21/64 59	5/8 M 16	UK 211 211 211 211	H 2311 HA 2311 HE 2311 HS 2311	P 211	3.46	7.61
UKP 212 + H 2312 + HS 2312	55 mm 2-1/8	2-3/4 69.8	5-7/16 138	63/64 25	9-1/2 241	7-1/4 184	2-3/4 70	25/32 20	29/32 23	1.2205 31	2-7/16 62	5/8 M 16	UK 212 212	H 2312 HS 2312	P 212	4.95	10.89
UKP 213 + H 2313 + HA 2313 + HE 2313 + HS 2313	60 mm 2-3/16 2-1/4 2-3/8	3 76.2	5-29/32 150	1-1/16 27	10-7/16 265	8 203	2-3/4 70	63/64 25	1-3/32 28	1.2598 32	2-9/16 65	3/4 M 20	UK 213 213 213 213	H 2313 HA 2313 HE 2313 HS 2313	P 213	5.06	11.13
UKP 215 + H 2315 + HA 2315 + HE 2315	65 mm 2-7/16 2-1/2	3-1/4 82.6	6-3/8 162	1-3/32 28	10-53/64 275	8-35/64 217	2-29/32 74	63/64 25	1-3/32 28	1.3976 35.5	2-7/8 73	3/4 M 20	UK 215 215 215	H 2315 HA 2315 HE 2315	P 215	7.27	15.99
UKP 216 + H 2316 + HA 2316 + HE 2316	70 mm 2-11/16 2-3/4	3-1/2 88.9	6-27/32 174	1-3/16 30	11-1/2 292	9-1/8 232	3-1/16 78	63/64 25	1-3/32 28	1.5354 39	3-5/64 78	3/4 M 20	UK 216 216 216	H 2316 HA 2316 HE 2316	P 216	8.36	18.39
UKP 217 + H 2317 + HA 2317 + HE 2317	75 mm 2-15/16 3	3-3/4 95.2	7-9/32 185	1-1/4 32	12-13/64 310	9-23/32 247	3-17/64 83	63/64 25	1-3/32 28	1.5748 40	3-15/64 82	3/4 M 20	UK 217 217 217	H 2317 HA 2317 HE 2317	P 217	10.23	22.51
UKP 218 + H 2318	80 mm	4	7-51/64	1-19/64	12-7/8	10-5/16	3-15/32	1-1/16	1-3/16	1.6535	3-25/64	7/8 M 22	UK 218	H 2318	P 218	12.34	27.15